

FORESTIER

Pendant Lamp

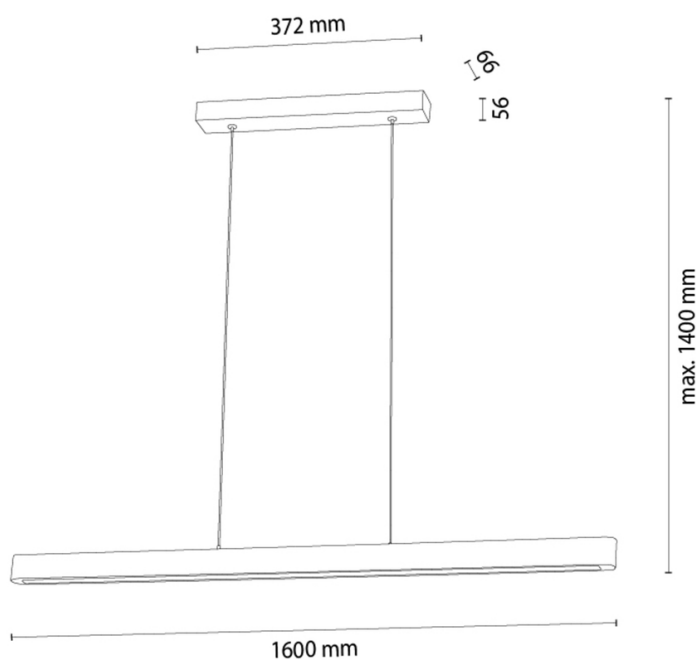

Article number:	1015133200000
EAN:	5905840267857
Light source:	1xLED 12V Integrated
LED power W:	23
AC voltage:	220-240V
Luminous power lm:	981 lm
Color temperature K:	3000K
Color rendering index CRI:	CRI ≥ 80
IP protection class:	IP20
Protection class:	2
Up&Down system:	TAK
Touch dimmer:	TAK
Click&Dimm system:	N/A
Magnetic mounting:	N/A
LED lighting method:	Direct LED lighting
Lamp material:	Metal, Stained pine
Lamp color:	Black, Brown
Lampshade No.:	N/A
Lampshade material:	N/A
Lampshade color:	N/A
Cable material:	Synthetic
Cable color:	Transparent
CE Declaration:	Download
FSC certificate:	FSC-C129231
Lamp dimensions	
Height (mm):	1100
Width (mm):	50
Length (mm):	1180
Diameter (mm):	
Net weight kg:	1,26
Gross weight kg:	1,57
Dimensions of carton No.1	
Height (mm):	90
Width (mm):	170
Length (mm):	1200
Dimensions of carton No.2	
Height (mm):	N/A
Width (mm):	N/A
Length (mm):	N/A
Dimensions of carton No.3	
Height (mm):	N/A
Width (mm):	N/A
Length (mm):	N/A



Made in Poland · 5 Years Guarantee