

FORESTIER

Pendant Lamp

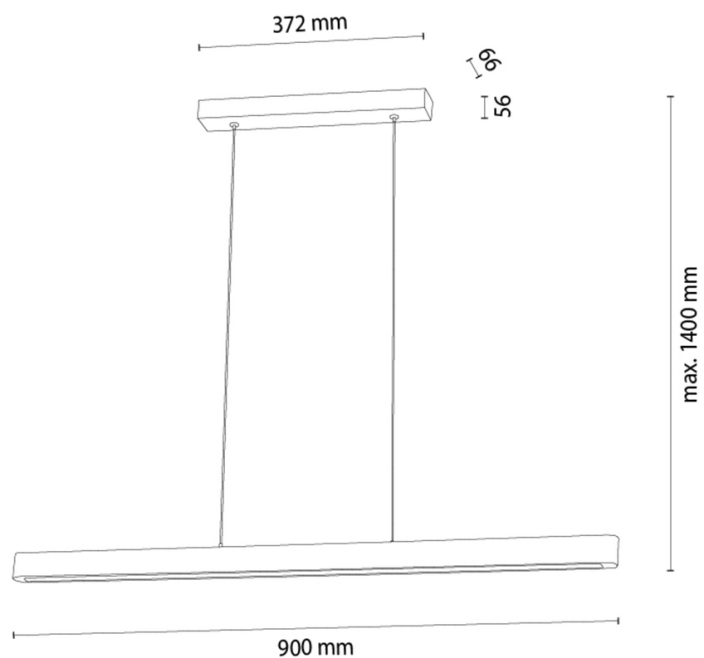

Article number:	1017413500000
EAN:	5905575050748
Light source:	1xLED 12V Integrated
LED power W:	17
AC voltage:	220-240V
Luminous power lm:	741 lm
Color temperature K:	3000K
Color rendering index CRI:	CRI ≥ 80
IP protection class:	IP20
Protection class:	2
Up&Down system:	N/A
Touch dimmer:	TAK
Click&Dimm system:	N/A
Magnetic mounting:	N/A
LED lighting method:	Direct LED lighting
Lamp material:	Metal, Oak wood
Lamp color:	Black, Oiled Oak
Lampshade No.:	N/A
Lampshade material:	N/A
Lampshade color:	N/A
Cable material:	Synthetic
Cable color:	Transparent
CE Declaration:	Download
FSC certificate:	FSC-C129231
Lamp dimensions	
Height (mm):	1100
Width (mm):	50
Length (mm):	900
Diameter (mm):	
Net weight kg:	1,06
Gross weight kg:	1,32
Dimensions of carton No.1	
Height (mm):	60
Width (mm):	120
Length (mm):	910
Dimensions of carton No.2	
Height (mm):	N/A
Width (mm):	N/A
Length (mm):	N/A
Dimensions of carton No.3	
Height (mm):	N/A
Width (mm):	N/A
Length (mm):	N/A



Made in Poland · 5 Years Guarantee