

# MERCEDES

## Pendant Lamp

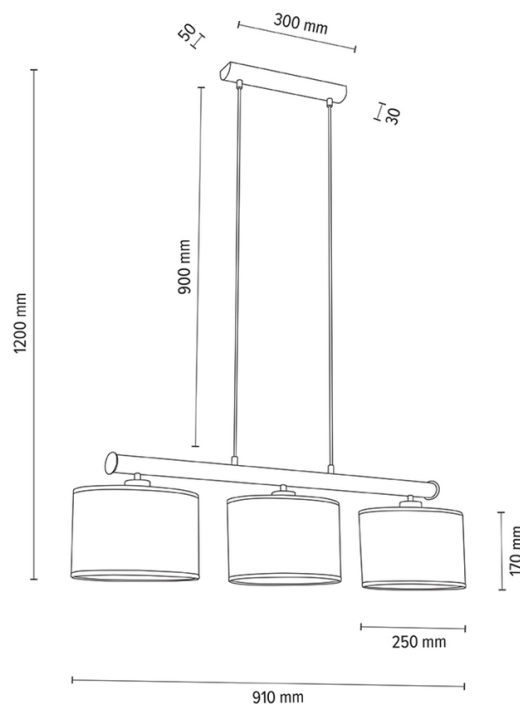

Article number:	1037400111525
EAN:	5905840252716
Light source:	3xE27 Max.40W
LED power W:	N/A
AC voltage:	220-240V
Luminous power lm:	N/A
Color temperature K:	N/A
Color rendering index CRI:	N/A
IP protection class:	IP20
Protection class:	2
Up&Down system:	N/A
Touch dimmer:	N/A
Click&Dimm system:	N/A
Magnetic mounting:	N/A
LED lighting method:	N/A
Lamp material:	Metal, Oak wood
Lamp color:	Nickel Matt, Oiled Oak
Lampshade No.:	A1525
Lampshade material:	Jacquard fabric
Lampshade color:	Cream-Silver
Cable material:	PVC
Cable color:	Transparent
CE Declaration:	<a href="#">Download</a>
FSC certificate:	<a href="#">FSC-C129231</a>
Lamp dimensions	
Height (mm):	1200
Width (mm):	175
Length (mm):	910
Diameter (mm):	
Net weight kg:	1,60
Gross weight kg:	2,70
Dimensions of carton No.1	
Height (mm):	220
Width (mm):	310
Length (mm):	950
Dimensions of carton No.2	
Height (mm):	n/a
Width (mm):	n/a
Length (mm):	n/a
Dimensions of carton No.3	
Height (mm):	n/a
Width (mm):	n/a
Length (mm):	n/a



Made in Poland · 5 Years Guarantee